

# Condition Monitoring and Analysis Method of Smart Substation Equipment Based on Deep Learning in Power Internet of Things

Lishuo Zhang, State Grid Hebei Extra High Voltage Company, China\*

 <https://orcid.org/0000-0001-5340-2474>

Zhuxing Ma, State Grid Hebei Extra High Voltage Company, China

Hao Gu, State Grid Hebei Extra High Voltage Company, China

Zizhong Xin, State Grid Hebei Extra High Voltage Company, China

Pengcheng Han, State Grid Hebei Extra High Voltage Company, China

## ABSTRACT

An accurate perception of the state of smart substation equipment is a strong guarantee for the reliable operation of the large power grid. This article proposes using deep learning for the device condition monitoring and analysis method in a power internet of things cloud edge collaboration mode. The speeded up robust features (SURF) feature detector is used at the edge of the network to accurately collect the interest points from the image data set, providing a reliable and complete sample data set support for the cloud-based deep learning network. Adding the attention mechanism module to the cloud improves the Yolov5 network model, enhance feature extraction, and increase the monitoring and analysis capabilities of the equipment. The simulation results show that the proposed method has achieved a recall rate of 91.21% and an accuracy rate of 90.54% for insulator fault evaluation indicators.

## KEYWORDS

Convolutional Block Attention, Deep Learning, Surf, The Power Internet of Things, Smart Substation, Yolov5 Network

## INTRODUCTION

The power equipment at smart substations plays a key role in transmitting electric energy. The stable operation and the transmission of electric energy greatly impact the substation equipment's life, performance, safety, and other factors (Wang et al., 2022). During actual operation, power equipment will be affected by overload, overvoltage, internal insulation aging, abnormal natural environment and other events, and abnormal operation status will lead to equipment defects and failures (Ye et al., 2022).

As a key component of the power system, power equipment will not only affect the power equipment itself, but also have an immeasurable impact on the large power grid system when serious

DOI: 10.4018/IJITSA.324519

\*Corresponding Author

This article published as an Open Access article distributed under the terms of the Creative Commons Attribution License (<http://creativecommons.org/licenses/by/4.0/>) which permits unrestricted use, distribution, and production in any medium, provided the author of the original work and original publication source are properly credited.

faults occur (He et al., 2022). Therefore, the reliability of power equipment in smart substations must receive due attention, particularly in increasingly complex power systems.

Traditional power equipment status recognition is realized through regular inspection by operation and maintenance personnel, which makes it difficult to realize the timely perception of the status of power equipment, and the increasing power load will also cause the lines and supporting power equipment at various voltage levels to go up in the station (Yang et al., 2021). The surge in patrol inspection workload overwhelms the operation and maintenance personnel, and the inspection of some electrical equipment could be wrongly performed.

The traditional planned maintenance method can hardly obtain the operation status and health status of power equipment in smart substations with accuracy and reliability. "Condition-based maintenance" has become a prevailing trend for the maintenance system. Furthermore, the trend of combing information and energy technology has provided new solutions for power equipment condition monitoring (Liu P. et al., 2020).

The power Internet of Things (pIoT) can realize resource integration of substation communication system and power system (Han, 2021; Long, 2022; Hason et al., 2021), collect the effective image data set of the state quantity of the power equipment with multiple types of terminal intelligent devices, and achieve accurate analysis of the equipment state through intelligent algorithms (Lei et al., 2022). Chen et al. (2020) describes the application of pIoT technology in equipment lifecycle research, compares and analyzes the traditional maintenance methods based on time. LuXH et al. (2022) realized the health detection of power equipment by optimizing and upgrading the network security processor. Wang et al. (2021) placed multiple sensors in the power transformer, built the Internet of Things network in the station, and established a mathematical model of power transformer fault diagnosis to achieve state monitoring and analysis.

Machine vision technology and deep learning technology can be introduced to help realize power equipment's condition monitoring and analysis. Deep learning can realize intelligent analysis of image data sets of acquisition equipment in the pIoT, extract and analyze information features of sample data through multi-layer network structure, and achieve analysis and judgment of equipment status (Hou et al., 2019; Liu et al., 2020; Davari et al., 2022). Zheng et al. (2021) introduced a feature pyramid to obtain image information features, and uses clustering algorithms to change the sliding frame of image analysis adaptively. Su et al. (2022) collected a video dataset and used a pyramid module to capture information of interest, obtaining an effective dataset and reducing the computational complexity of the model. Based on the Yolov4 network model, real-time status evaluation of transformers was achieved. Liu et al. (2022) used Yolov4 network-based analysis for infrared image datasets, analyzed the impact of relevant factors on target detection performance, and established the optimal detection model. Zhao et al. (2021) adopted a limited sliding network (LSNet) to achieve regional and centralized defect detection, and uses the STYLE model and non-maximum suppression method to locate the target and enrich the features of the image, achieving accurate classification. Ullah et al. (2020) combined random forest algorithm and support vector machine, extracts rich feature maps from the convolution layer of AlexNet pre training model, and trains random forest (RF) and support vector machine (SVM) to learn defective and non-defective high-voltage electrical equipment, to achieve early prevention and analysis of thermal anomalies of electrical equipment.

However, it should be noted that good public data set for power equipment images is not available because of the particularity and confidentiality of smart substations, and the small data sample set entails processing the data set. Meanwhile, given that the defect ratio of power equipment may be smaller than that of equipment size, it is necessary to enhance the ability of deep network model to extract key information features.

Aiming to meet the requirement of condition detection of a huge amount of equipment in smart substations, this paper proposes an equipment condition monitoring and analysis method based on the pIoT architecture. The innovations involved in the article include:

1. To ensure efficient preprocessing of image data, the image processing capability of traditional cloud centers is lowered to the edge of the network, and the data universality is enhanced based on geometric transformations and other processing methods. Furthermore, at the edge of the network, the Speed Up Robust Features (SURF) feature detector is used to collect interest points in the image dataset accurately.
2. On the cloud center side of the Power Internet of Things, build a Yolov5 optimized network and introduce a convolutional attention mechanism module to focus on the content that needs to be located, enhance the feature extraction ability of the image analysis network, and obtain more useful feature information.

## SMART SUBSTATION PIOT ARCHITECTURE

In the pIoT context, the perception layer's multi-dimensional state information is often huge in quantity and has many attributes (Lee & Lee, 2020). To meet the demand of pIoT for "real-time state perception and real-time data acquisition" of smart substation equipment (Shao & Chen, 2022; Wei et al., 2021), cloud computing and edge computing are combined to build the collaborative smart substation power IoT architecture.

The pIoT and artificial intelligence have promoted the emergence of edge computing. The combination has greatly improved the data processing capabilities of cloud computing centers and edge intelligent terminals (Zhang et al., 2021; Xu et al., 2020).

The smart substation equipment status detection architecture based on cloud edge collaboration mode is shown in Figure 1.

As shown in Figure 1, the smart substation pIoT terminal device can realize the collection and uploading of the equipment status data set of the substation, including the electrical quantity data set and non-electrical quantity data set. The smart substation is different from the traditional substation. The smart substation's intelligent control cabinet, protection and monitoring devices can upload rich electrical data through optical fiber. In addition, modern substations are fitted with equipment such as patrol robots, drones, etc., which can help achieve reliable uploading of image data sets. Therefore, heterogeneous and massive data sets can effectively support the cloud and edge side of the pIoT to achieve reliable and rapid equipment status detection and analysis.

The intelligent computing device on the edge side of the pIoT can realize fast analysis close to the data side. Multiple edge computing devices are set in the smart substation to preprocess the

Figure 1. Cloud edge collaborative structure of smart substation

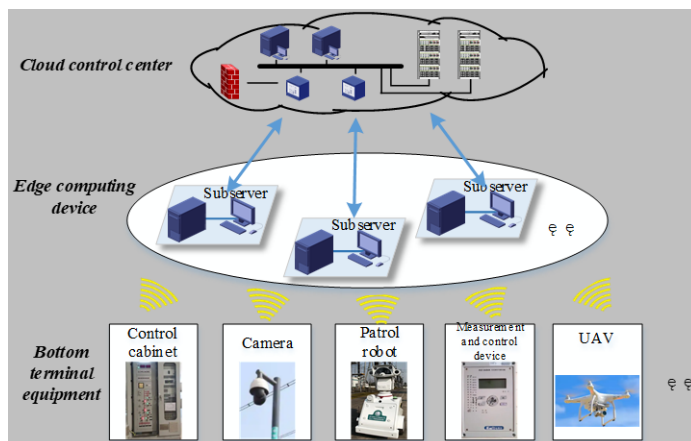

equipment status acquisition data (Chen et al., 2021). Simultaneously, the cloud center will sink some of its computing power to the edge computing equipment. At the edge of the smart substation, it is possible to quickly perceive the network status and accurately study and judge the equipment status. The edge intelligent computing terminal of the power Internet of Things can be placed in the main control room of each intelligent substation, achieving fast and efficient data processing and calculation at the station end, and delegating decision-making and data to the intelligent terminal or monitoring terminal.

The power IoT cloud computing control center will be placed at the operation monitoring terminal to organize and analyze the data collected by the underlying intelligent terminals. The smart substation pIoT cloud center has strong computing power. Based on big data technology, the cloud center platform can realize advanced applications such as intelligent switching operation, one key sequential control, and equipment fault detection. In addition, the operation and maintenance personnel in the station can also perceive and control the equipment in the station based on the cloud center platform.

## **STATE ANALYSIS METHOD OF SMART SUBSTATION EQUIPMENT BASED ON THE YOLOV5 NETWORK MODEL**

This paper aims to realize the detection and analysis of the equipment's status in the pIoT station. Data enhancement and interest point acquisition are used to extract the image feature information at the edge of the network. The CBAM - Yolov5 image analysis model is built in the network cloud center based on the convolutional block attention module and Yolov5 network to achieve accurate and efficient status analysis of power equipment in the station.

### **Edge Side Data Processing**

#### *Image Enhancement*

On the edge side of the pIoT, the intelligent device expands the number of training image data sets, eliminates the hidden danger of over fitting during model training, and strengthens the diversified training of network models by high-voltage transmission line fault data sets.

Data enhancement can ensure that the image information of the original dataset remains intact with more target feature information extracted repeatedly from the original data samples. Moreover, the network model can also learn and train the enhanced data more fully and absorb more feature information, thus effectively enhancing the robustness and generalization ability to target detection.

In the geometric transformation, this paper mainly adopts such geometric transformation methods as flipping, translation, scaling, and rotation. The geometric transformation is shown in Figure 2.

Adjusting the image brightness during color transformation can better simulate the light change of the substation equipment fault image obtained through aerial photography. Adjusting the image contrast can highlight the fault target contour, showing more vivid and rich target information of the image. Adjusting the image saturation can weaken the background content similar to the fault target but not the fault target in the image. Color transformation is shown in Figure 3.

Various transformations are carried out based on the actual conditions of different images via data enhancement processing to achieve the diversity and representativeness of data samples, which allows network training to learn more equipment status feature details.

#### *Collection of Interest Points*

Further, used at the edge of the pIoT to collect the interest points of the image dataset, SURF can better capture the effective information features in the substation equipment image, and then send the image features to the cloud-trained depth learning classifier to obtain the equipment status.

As a feature detector, SURF can detect objects' recognition and arrangement, and perform image processing by using three integer operations of pre-configured basic pictures.

Figure 2. Enhancement of geometric changes of acquired images

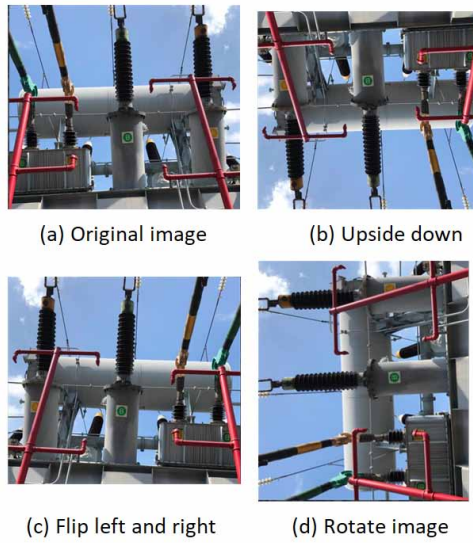
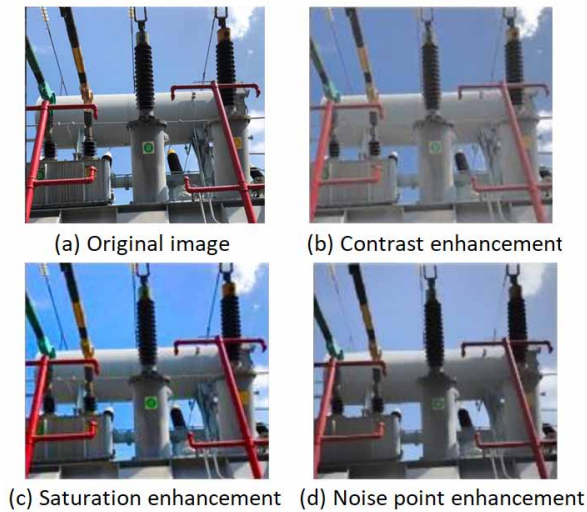

Figure 3. Color transformation enhancement of acquired image



SURF describes how to find and perceive objects and focuses on tracking objects. The interest point detection and scale are shown as follows.

1. Point of interest detection.

SURF uses a square filter to estimate Gaussian smoothing, which is characterized by:

$$\delta(i, j) = \sum_{i=0} \sum_{j=0} P(i, j) \quad (1)$$

where,  $P(i, j)$  is the point coordinate in the image. The main images in the rectangle can be added up quickly by using irreplaceable images.

This feature uses the blob identifier of the Hessian matrix to identify the key points. Instead of using the Hessian Laplacian locator, SURF uses the determinant of Hessian to select the scale, and Lindeberg to complete the positioning.

Suppose that point  $v(i, j)$  in graph  $L$  has the characteristics of Hessian matrix with scale  $u$  and point  $v$  :

$$H(u, v) = \begin{pmatrix} I_{ii}(u, v) & I_{ij}(u, v) \\ I_{ji}(u, v) & I_{jj}(u, v) \end{pmatrix} \quad (2)$$

In the formula,  $I_{ii}(u, v)$  is the second derivative in the grayscale image.

## 2. Scale space representation and interest point area.

Points of interest can be found in different scale-spaces. In different feature detection algorithms, the area of a dimension can usually be viewed as an image pyramid. SURF uses a Gaussian filter to smooth the image area numerous times, then samples it to achieve a higher pyramid level, the improvised interest point area.

## Cloud Equipment Status Analysis

Input the processed image dataset of the intelligent substation into the backbone network of the Yolov5 network for image slicing and re merging processing, achieving physical computational simplification. Then, the processed image is input into the Neck network to achieve deep extraction of image features. At the same time, it can be seen that there is a small amount of information loss and background noise impact when simplifying the image dataset calculation in the backbone network, which can cause bias when extracting data in the Neck network. Therefore, the CBAM network module is introduced into the backbone network to achieve differential processing and multi-dimensional extraction of image information.

### *Yolov5 Network Model*

YOLOv5 adopts a new backbone network architecture, namely CSPNet, which is better than YOLOv4 in computing efficiency and accuracy; Meanwhile, YOLOv5 adopts an SPP structure that can process multi-scale features, and introduces new technologies such as PAN structure and adaptive enhancement, improving the accuracy and efficiency of detection.

Figure 4 shows the network model of YOLOv5. The backbone mainly comprises the Focus structure and CSP structure. The Focus module performs the slicing operation on the image before entering the backbone, and then turns the  $320 \times 320 \times 6$  image into the  $180 \times 12$  feature map, as shown in Figure 5.

The  $640 \times 640 \times 2$  feature map is formed after the  $4 \times 4$  convolution operation, and the feature information of the original map is retained to the maximum extent while down sampling.

The Neck structure of YOLOv5 adopts the structure of multi-scale feature pyramid FPN+PANet. As shown in Figure 6, FPN enhances the semantic information by up sampling and shallow feature fusion of the deep feature map, while PANet from bottom to top samples the shallow feature map with strong location information and fuses the deep feature map to enhance the feature fusion capability of the Neck network.

Figure 4. Structure chart of YOLOv5

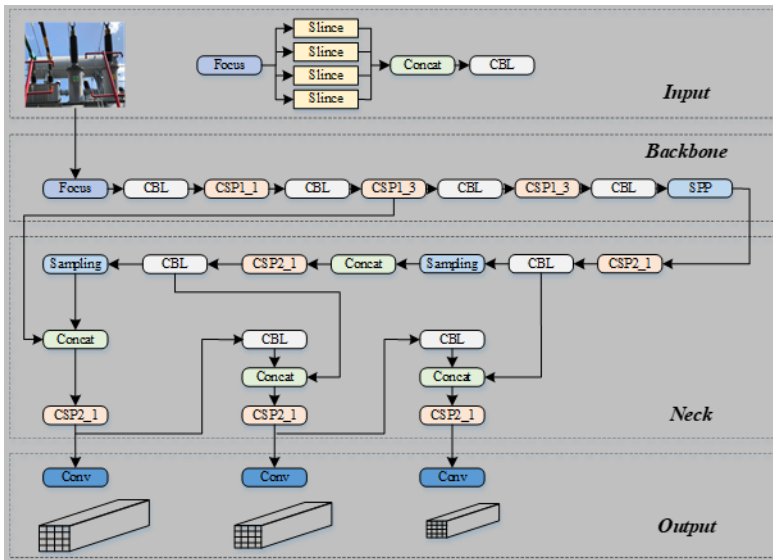

Figure 5. Structure chart of Focus

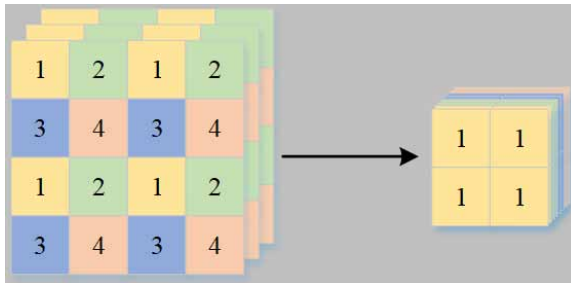
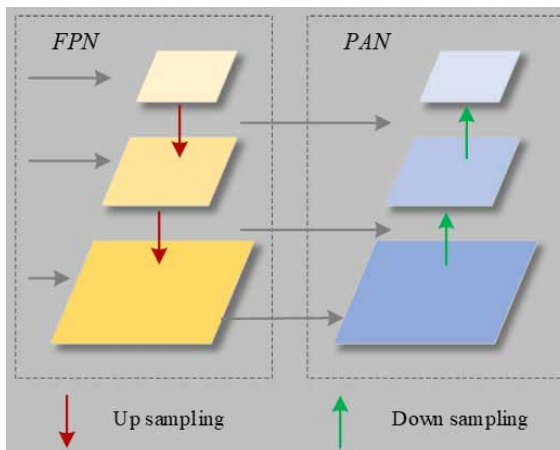

Figure 6. Structure chart of FPN+PAN



### Optimization of Feature Extraction Capability

YOLOv5 model is prone to the loss of small targets and interference from background in sampling. This paper, therefore, adds an attention mechanism to focus on the content to be located, and explores the optimization performance of attention mechanism on model performance.

CBAM is used in this paper to integrate time and space mapping processes with a hybrid attention mechanism to obtain more feature information. CBAM is a lightweight universal module that can seamlessly integrate into any CNN architecture compared to traditional attention mechanism modules, and can achieve synchronous training with CNN networks, making it widely applicable.

CBAM comprises two sub-modules: channel and spatial. The input feature map is processed on each convolution block in the depth network to obtain a complete feature map through two sub-modules successively. Figure 7 shows the structure of CBAM.

Given an input feature map  $L$  with size  $B \times W \times Y$ , CBAM deduces a one-dimensional feature map  $C_F$  with size  $B \times 1 \times 1$  and a two-dimensional feature map  $C_S$  with size  $1 \times W \times Y$  in sequence:

$$L' = C_F(L) \otimes L \tag{3}$$

$$L'' = C_S(L') \otimes L' \tag{4}$$

where,  $C_F(L)$  is the output attention diagram of the channel attention module;  $\otimes$  stands for dot product, representing the product of corresponding elements of two matrices;  $C_S(L')$  is the output attention map;  $L''$  is the feature map output.

Figure 8 shows the block diagram of each attention sub module in the CRAM module. The channel sub-module uses MaxPool and AvgPool to output a shared network.

CBAM first aggregates the spatial information through MaxPool and AvgPool, and generates two spatial descriptors after calculation:  $L_{avg}$  and  $L_{max}$ . The two descriptors represent the corresponding channel feature map.

Channel Note Figure  $C_F(L)$  is calculated as follows:

$$\begin{aligned} C_F(L) &= \delta(MLP(AvgPool(L)) \\ &\quad + MLP(MaxPool(L))) \\ &= \delta(S_1(S_0(L_{avg})) + S_1(S_0(L_{max}))) \end{aligned} \tag{5}$$

Figure 7. Model structure block diagram of CBAM

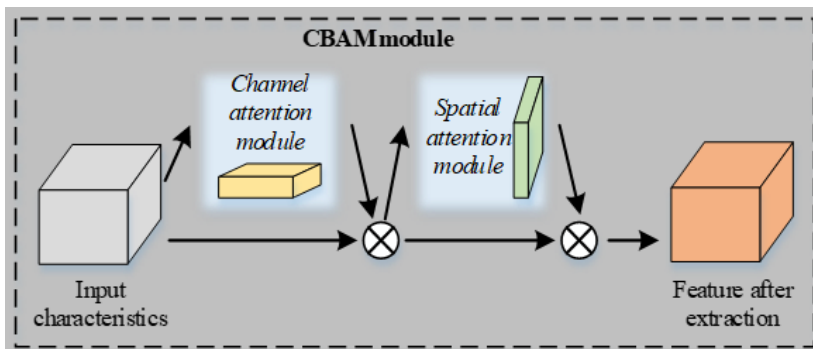
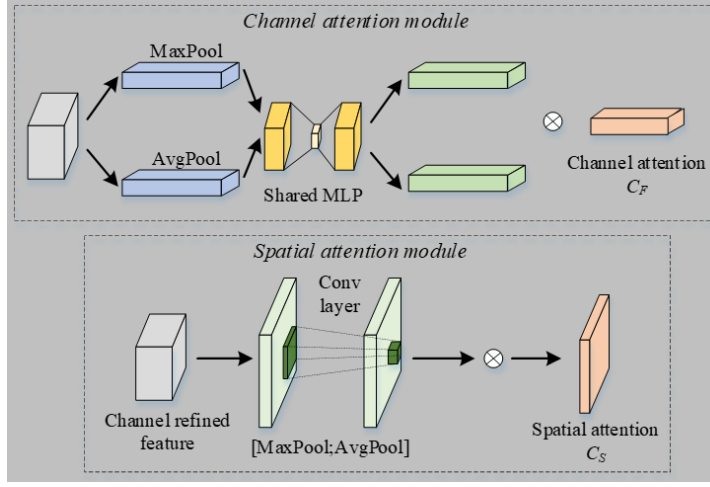



Figure 8. Attention sub-module



The MaxPool and AvgPool two-step operations can effectively generate feature descriptors, thereby effectively highlighting the information region. Then, the  $6 \times 6$  convolution layer is used to convolution the generated two feature maps to generate a two-dimensional spatial attention map. The calculation method is as follows:

$$\begin{aligned} C_S(L) &= \delta(l^{6 \times 6}([AvgPool(L); MaxPool(L)])) \\ &= \delta(l^{6 \times 6}([L_{avg}; L_{max}])) \end{aligned} \quad (6)$$

The attention module of the space and channel modules enables multi-dimensional processing of information and more accurate and faster feature locating.

### Optimization of Loss Function

Due to the problem of partial occlusion in the collected infrared images of power equipment, the distance between some power equipment is relatively short. Therefore, the loss function in this paper adopts improved DIOU\_ as a loss function, and NMS replaces the slow convergence GIOU loss function, effectively solving the problem of occlusion of the power equipment image to be detected.

The loss calculation formula of DIOU is as follows:

$$L_{DIOU} = 1 - 0.5 + R_{DIOU}(U, U') \quad (7)$$

where,  $R_{DIOU}(U, U')$  is the penalty item of prediction box  $U$  and target box  $U'$ , and the specific calculation is as follows:

$$R_{DIOU} = \frac{\rho^2(u, u')}{e^2} \quad (8)$$

where,  $u$  and  $u'$  represent the center points of  $U$  and  $U'$ ;  $\rho$  stands for Euclid distance.

The specific definitions are:

$$d = \rho^2(u, u') \tag{9}$$

### Status Analysis Process

Relying on the proposed architecture, this paper preprocesses the image sample data set at the edge side, and further sends it to the pIoT cloud center to detect and analyze the equipment status used the CBAM-Yolov5 network model, and to understand the equipment status, and take corresponding measures.

The flow chart of the smart substation equipment status detection method proposed is displayed in Figure 9.

The proposed image detection method mainly consists of the following five steps:

- Step 1:** The intelligent terminal realizes the collection of image sample data sets of power equipment.
- Step 2:** The expression of feature information of the dataset is strengthened at the edge of the network through the operation of geometric change and color transformation.
- Step 3:** SURF is used at the edge of the pIoT to collect the interest points of the image dataset, which allows better capturing of the effective information features in the substation equipment images.
- Step 4:** The CBAM-Yolov5 network model is used in the network cloud to build the equipment status detection model, which facilitates an accurate real-time analysis of the health status of power equipment.
- Step 5:** Output the final state determination results of the power equipment.

## SIMULATION EXPERIMENT ANALYSIS

The experimental environment built in this paper is shown in Table 1, including hardware environment and software environment.

Figure 9. Method flow chart

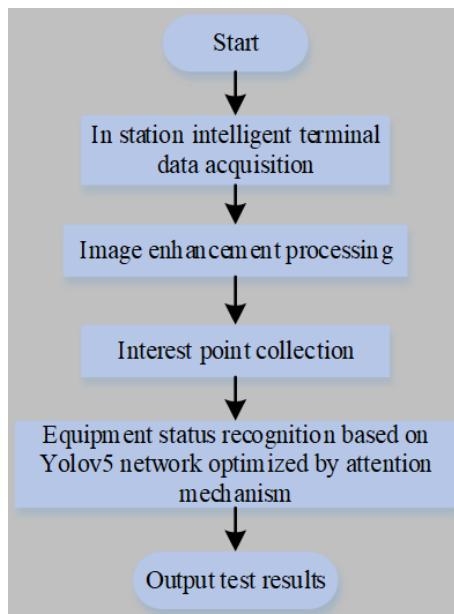

**Table 1. Simulation experiment setup environment**

Project	Parameter
CPU processor	Intel Core i5-8400
GPU	GTX 3060
Memory	8G DDR4
Operating system	Windows 10
Programming environment	Pycharm
Python version	Python 3.6
Pytorch version	Pytorch 1.6
CUDA Version	10.2
Graphic database	Neo4j

The main network parameter settings of CBAM-Yolov5 image analysis model are shown in Table 2.

Aiming to ensure the universality of the detection categories, this paper studies the power supply equipment and transmission equipment of smart substations from large to small, including the external equipment and small parts, which mainly cover the following five categories: conservator, insulator, bushing, bolt, and current transformer.

The data sample set includes 350 training images and 150 test images with resolutions ranging from  $100 \times 100$  to  $5000 \times 5000$ .

### Convergence and Divergence Analysis of the Model

This paper analyzes the convergence and divergence of CBAM-Yolov5 image analysis model, and uses Yolov5 network structure as a comparison model for analysis. Each experiment was conducted 10 times, and the final results were taken as an average of 10 tests.

Figure 10 shows how the loss value of CBAM-Yolov5 and Yolov5 varies with the iteration number. As can be seen from Figure 10, with the convolutional attention mechanism module it introduces, CBAM-Yolov5 allows the proposed device detection method to achieve faster and more accurate image feature extraction than Yolov5, thus reducing the amount of network computing. Therefore, the training loss value of the network converges faster, reflecting a strong ability to jump out of the local optimal solution.

### Evaluation Index

The widely recognized Average Precision (AP) is used to measure performance. The evaluation cross over Union (IoU) is set to 0.5. The average precision is obtained by calculating the precision integral on different levels of recall. This standard is widely used in image analysis tasks:

**Table 2. CBAM-yolov5 network model parameters**

Project	Value
Learning rate	0.0015
Momentum factor	0.85
Weight attenuation	0.0006
Batch Size	32
Cross merger ratio	0.65
Number of training rounds	400

Figure 10. Loss comparison between CBAM-Yolov5 and Yolov5

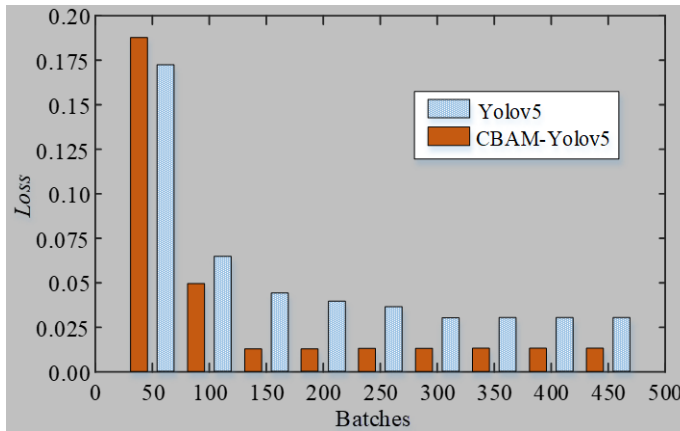

$$Precision = \frac{TP}{TP + FP} \tag{10}$$

$$Recall = \frac{TP}{TP + FN} \tag{11}$$

Among them,  $TP$  is the number of correctly predicted positive samples;  $FP$  is to predict the negative sample as true;  $FN$  refers to the number of undetected positive samples predicted as false.

### Method Performance Analysis

To demonstrate its superior performance, this paper uses the methods of Su et al. (2022) and Zhao et al. (2021) for comparison.

The deep network used in constructing recognition networks by Su et al. (2022) and Zhao et al. (2021) can achieve state recognition and fault detection in power equipment. Among them, Zhao et al. (2021) implemented defect detection of transmission lines based on LSNet networks, and Su et al. (2022) used the Yolov4 network to complete real-time analysis and evaluation of transformer status.

The state detection effect of insulator equipment in smart substations is shown in Figure 11.

It can be seen from Figure 11 that the proposed CBAM-Yolov5 network model for insulator fault analysis has a recall rate of 91.21%, which is 1.61% and 1.39% higher than that in Yolov4 network and LSNet network respectively. The accuracy rate is 90.54%, while the corresponding evaluation indicators of the comparison methods are less than 90%. The improvement relative to the comparison method is because of how this study uses a cloud edge collaboration analysis model, which places data preprocessing on the network edge side for implementation. The method based on data enhancement and interest point extraction improves the reliability and completeness of the sample data of the analysis model. At the same time, the CBAM attention mechanism module is introduced into the Yolov5 model in the cloud to achieve accurate acquisition of deep image features. The use of the loss function DIOU\_NM is used to replace the slow convergence GIOU loss function, which effectively solves the problem of occlusion of the power equipment image to be detected, and further improves the detection capability of the model.

Figure 11. Insulator status identification

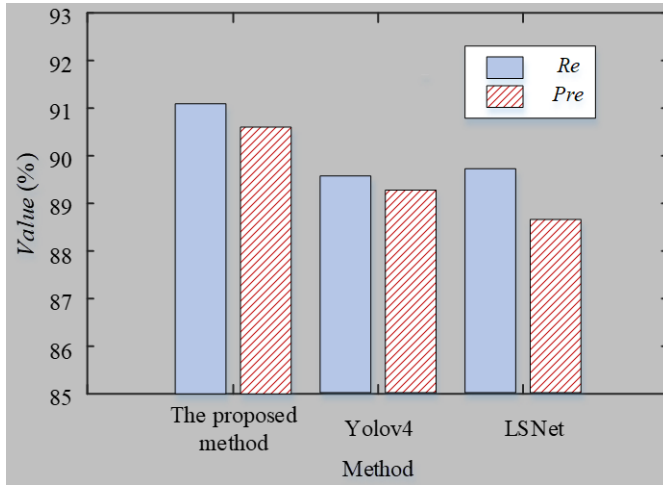

Furthermore, this paper also conducted research on the calculation and analysis efficiency of the method. Table 3 shows the calculation efficiency and identification accuracy of different methods. Table 3 shows the average identification accuracy of the proposed method for all equipment states in the sample set is 90.68%, which is 2.84% higher than that used Yolov4 network. However, the average identification accuracy of LSNet network is 89.59%, which is close to the identification performance of the proposed method. However, for the time of image analysis, the calculation cost of LSNet network is 1.541s, which is 0.44s more than that of the proposed method.

Our results show that the cloud edge collaboration model based on the pIoT in this paper sinks part of the computing and analysis capabilities to the network's edge. This approach can greatly enhance the computing and analysis performance of the entire network model and achieve the optimization of computing and analysis efficiency.

## CONCLUSION

Based on the pIoT architecture, this paper proposes a smart substation equipment condition monitoring and analysis method based on deep learning. SURF detector and image enhancement are used to improve the reliability and completeness of the sample data set based on the edge computing device. The cloud center can effectively perceive and accurately analyze equipment status when using the CBAM-Yolov5 network model. The experimental simulation results prove that the proposed method has exemplary state monitoring capability for power equipment in smart substations.

Although the simulation results prove that the proposed method has excellent network performance, it should also be emphasized that all the analyzed sample data sets were acquired under

Table 3. Identification accuracy and calculation efficiency

Method	Accuracy (%)	Time (s)
The proposed method	90.68	1.101
Yolov4 network	87.84	1.357
LSNet network	89.59	1.541

good weather conditions. The follow-up research, therefore, should conduct research and analysis on equipment state perceptions in varying and complex weather environments.

## **FUNDING INFORMATION**

Science and technology project supported by State Grid Corporation of China (Grant No.kj2021-054).

## REFERENCES

- Chen, H. Y., Cai, W. J., & Chen, J. R. (2021). Power internet of things technology with energy and information fusion. *Power System Protection and Control*, 49(22), 8–17. doi:10.19783/j.cnki.pspc.202163
- Chen, S. Y., Guo, Y. N., Sun, W., Zhang, K., Li, L., & Tan, L. (2020). A new approach to the application of condition-based maintenance technology of power equipment in smart grid. *International Conference of Recent Trends in Environmental Sustainability and Green Technologies (ICRTEG)*, (pp. 1-7). doi:10.1051/e3sconf/202020402013
- Davari, N., Akbarizadeh, G., & Mashhour, E. (2022). Corona detection and power equipment classification based on GoogleNet-AlexNet: An accurate and intelligent defect detection model based on deep learning for power distribution lines. *IEEE Transactions on Power Delivery*, 37(4), 2766–2774. doi:10.1109/TPWRD.2021.3116489
- Han, Q. H. (2021). Research on the construction of cold chain logistics intelligent system based on 5G Ubiquitous Internet of Things. *Journal of Sensors*, 2021(1), 6558394. doi:10.1155/2021/6558394
- Hasan, M. K., Islam, S., Shafiq, M., Ahmed, F. R. A., Ataelmanan, S. K. M., Babiker, N. B. M., & Abu Bakar, K. A. (2021). Communication delay modeling for wide area measurement system in smart grid Internet of Things networks. *Wireless Communications and Mobile Computing*, 2021(1), 9958003. doi:10.1155/2021/9958003
- He, L. F., Li, L., Li, M., Li, Z., & Wang, X. (2022). A deep learning approach to the transformer life prediction considering diverse aging factors. *Frontiers in Energy Research*, 10, 930093. doi:10.3389/fenrg.2022.930093
- Hou, R., Zhao, Y., Tian, S., Yang, Y., & Wenhai, Y. (2019). Fault point detection of IOT using multi-spectral image fusion based on deep learning. *Journal of Visual Communication and Image Representation*, 64(C), 1–8. doi:10.1016/j.jvcir.2019.102600
- Lee, H., & Lee, B. (2020). The development of a state-aware equipment maintenance application using sensor data ranking techniques. *Sensors (Basel)*, 20(11), 3038. doi:10.3390/s20113038 PMID:32471125
- Lei, T. X., Lv, F. C., Liu, J. M., & Feng, J. (2022). Research on electrical equipment monitoring and early warning system based on Internet of Things technology. *Mathematical Problems in Engineering*, 2022(1), 6255277. doi:10.1155/2022/6255277
- Liu, P., Zhang, Y. F., Wu, H., & Fu, T. T. (2020). Optimization of Edge-PLC based Fault Diagnosis with Random Forest in Industrial Internet of Things. *IEEE Internet of Things Journal*, 7(10), 9664–9674. doi:10.1109/JIOT.2020.2994200
- Liu, T., Li, G. L., & Gao, Y. (2022). Fault diagnosis method of substation equipment based on You Only Look Once algorithm and infrared imaging. *Energy Reports*, 8(1), 171–180. doi:10.1016/j.egy.2022.05.074
- Liu, Y., Xinxin, J. I., Pei, S., Ma, Z., Zhang, G., Lin, Y., & Chen, Y. (2020). Research on automatic location and recognition of insulators in substation based on YOLO-v3. *High Voltage*, 5(1), 62–68. doi:10.1049/hve.2019.0091
- Long, L. (2022). Research on status information monitoring of power equipment based on Internet of Things. *Energy Reports*, 8(2), 281–286. doi:10.1016/j.egy.2022.01.018
- Lu, X. H., Lu, Y. H., Luo, L. H., Lin, W., & Zhang, J. (2022). Remote data acquisition and management technology of power equipment based on Internet of Things. *Mobile Information Systems*, 2022(1), 3902541. doi:10.1155/2022/3902541
- Shao, N., & Chen, Y. (2022). Abnormal data detection and identification method of distribution internet of things monitoring terminal based on spatiotemporal correlation. *Energies*, 15(6), 2151. doi:10.3390/en15062151
- Su, L., Huang, H., Qin, L. M., & Zhao, W. (2022). Transformer vibration detection based on YOLOv4 and Optical Flow in background of high proportion of renewable energy access. *Frontiers in Energy Research*, 10, 1–14. doi:10.3389/fenrg.2022.764903
- Ullah, I., Khan, R. U., Yang, F., & Wuttisittikulij, L. (2020). Deep learning image-based defect detection in high voltage electrical equipment. *Energies*, 13(2), 392. doi:10.3390/en13020392
- Wang, G., Liu, Y., Chen, X., Yan, Q., Sui, H., Ma, C., & Zhang, J. (2021). Power transformer fault diagnosis system based on Internet of Things. *EURASIP Journal on Wireless Communications and Networking*, 2021(1), 21. doi:10.1186/s13638-020-01871-6

- Wang, J. (2021). Full-scene network security protection system based on ubiquitous power Internet of things. *International Journal of Communication Systems*, 35(3), e4695. doi:10.1002/dac.4695
- Wang, W., Wang, R. Q. Y., Zhang, H., Zhou, Z., & He, Y. (2022). Matching learning-based relay selection for substation power Internet of Things. *Wireless Communications and Mobile Computing*, 2022(1), 6795205. doi:10.1155/2022/6795205
- Wei, L. X., Chen, Y. R., Wang, H., Li, M., Liu, Z., Wang, Y., Luo, Q., & Chen, L. (2020). BBIL: A bounding-based iterative method for IoT to localize things. *IEEE Internet of Things Journal*, 7(2), 1413–1425. doi:10.1109/JIOT.2019.2955115
- Xu, C., Yang, H. H., Wang, X., & Quek, T. Q. S. (2020). Optimizing information freshness in computing enabled IoT networks. *IEEE Internet of Things Journal*, 7(2), 971–985. doi:10.1109/JIOT.2019.2947419
- Yang, Y., & Yao, L. (2021). Optimization method of power equipment maintenance plan decision-making based on deep reinforcement learning. *Mathematical Problems in Engineering*, 2021(1), 9372803. doi:10.1155/2021/9372803
- Ye, B., Li, F., Li, M. X., Yan, P., Yang, H., & Wang, L. (2022). Intelligent detection method for substation insulator defects based on Center Mask. *Frontiers in Energy Research*, 10, 985600. doi:10.3389/fenrg.2022.985600
- Zhang, J., Zhu, W., Wu, X., & Ma, T. (2021). Traffic state detection based on multidimensional data fusion system of Internet of Things. *Wireless Communications and Mobile Computing*, 2021(1), 1374186. doi:10.1155/2021/1374186
- Zhao, J., Zhang, K., Wang, Z. H., Liu, F., Sun, G., Chou, J., Xu, M., Zhang, X., Liu, X., & Li, Z. (2021). Limited sliding network: Fine-grained target detection on electrical infrastructure for power transmission line surveillance. *International Journal of Circuit Theory and Applications*, 49(4), 1212–1224. doi:10.1002/cta.2906
- Zheng, H. B., Sun, Y. H., Liu, X. H., Djike, C. L. T., Li, J., Liu, Y., Ma, J., Xu, K., & Zhang, C. (2021). Infrared image detection of substation insulators using an improved fusion single shot multibox detector. *IEEE Transactions on Power Delivery*, 36(6), 3351–3359. doi:10.1109/TPWRD.2020.3038880

*Lishuo Zhang, born in 1989, holds the title of engineer, and his research direction is power system and its automation.*

*Zhuxing Ma, born in 1979, obtained a master's degree and the title of senior engineer. His main research direction is power system and its automation.*

*Hao Gu, male, born in 1989, is an engineer who mainly engages in research related to power systems and their automation.*

*Zizhong Xin, male, born in 1989, is an engineer who mainly studies power systems and their automation.*

*Pengcheng Han, male, born in 1986, holds the title of engineer and focuses on research in power systems and their automation.*